

Structure of microfiche

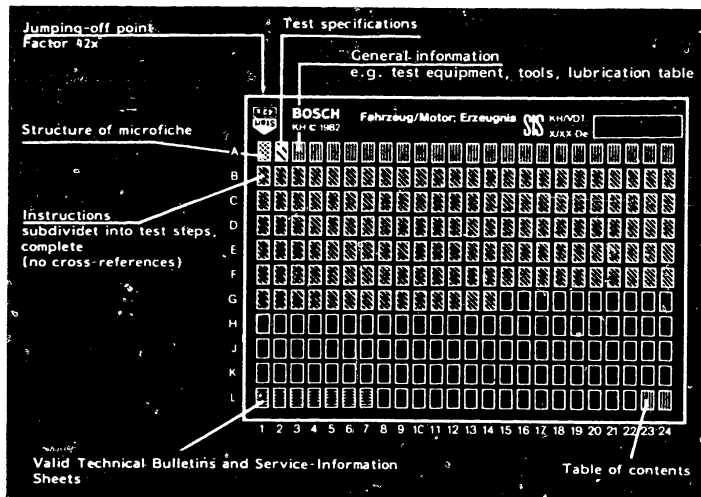

1. Read from left to right

2. Title of microfiche (appears on each coordinate)

E 16	Product/assembly/test step	
	Vehicle/engine	

Coordinate

3. Limits of section

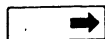

Beginning

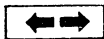

Mid-section



End



One-page section

4. References to relevant test steps in test specifications; coordinate e.g. C6

C6

A1

Testing



1. Test specifications

For test specifications see list of test-specification sheets VDT-W-231/1000 including test-specification sheets VDT-WPE 120/2...21 and VDT-W-231/1001 etc.

A2

Test specifications

ZV 0 231 ..., conv. to Hall generator



2. Necessary testers and auxiliary equipment

Distributor test bench ZVS 50	0 683 400 200
Distributor test adapter with accessories	KDZV 7202
Voltage stabilizer e.g. Gossen = 12 V/10 A or	Commercially available
Battery 12 V 84 Ah charged e.g.	0 183 058 411
Tachometer e.g. KTE 001.03	0 684 400 103
Voltmeter ETE 014.00 ($R_i \geq 50k \Omega/V$)	0 684 101 400
Voltmeter ETT 044 ($R_i \geq 50k \Omega/V$)	0 684 100 400
Voltmeter KTE 001.03 ($R_i \geq 50k \Omega/V$)	0 684 400 103
Voltmeter MOT 001.03 ($R_i \geq 50k \Omega/V$)	0 684 000 103
Voltmeter MOT 201 ($R_i \geq 50k \Omega/V$)	0 684 000 201
Voltmeter MOT 202 ($R_i \geq 50k \Omega/V$)	0 684 000 202
Multimeter (with mA measuring range)	Commercially available
Resistor 1.5 k Ω 1 W \pm 5%	Commercially available



3. Lubricants

Plain-bearing grease	Part numbers:
VS 14060 Ft 250g can	5 964 520 125
Rolling-bearing grease	
Ft 1V26 50g tube	5 700 005 005
Special oil	
01 1V13 0.5l can	5 962 260 605

3:1 Lubrication table

General

The following exploded views show the points which must be treated with the stated lubricants.

Pay particular attention to footnotes.

The exploded views cannot be used for the assembly of ignition distributors (incomplete).



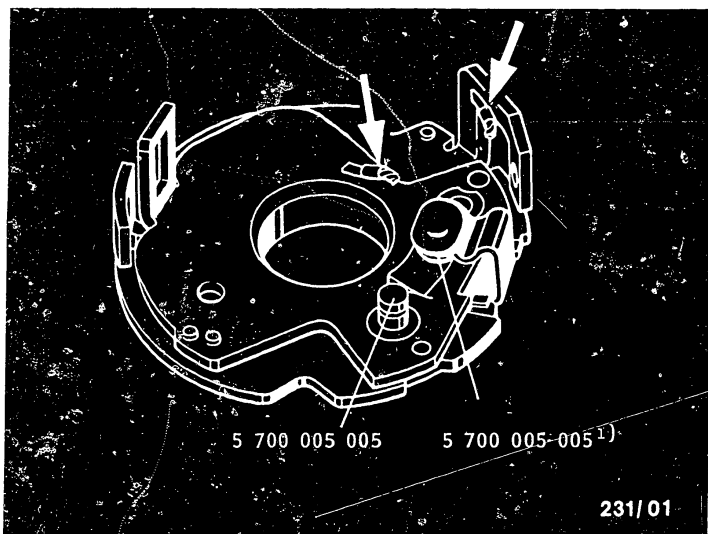

Lubrication points and lubricants on breaker-plate assembly.

- 1) Grease the running ball and sliding surfaces.
Distributor contact points are removed.
Ground connection (copper wire) is cut through
(arrows)

A5

Lubrication table

ZV 0 231 ..., conv. to Hall generator



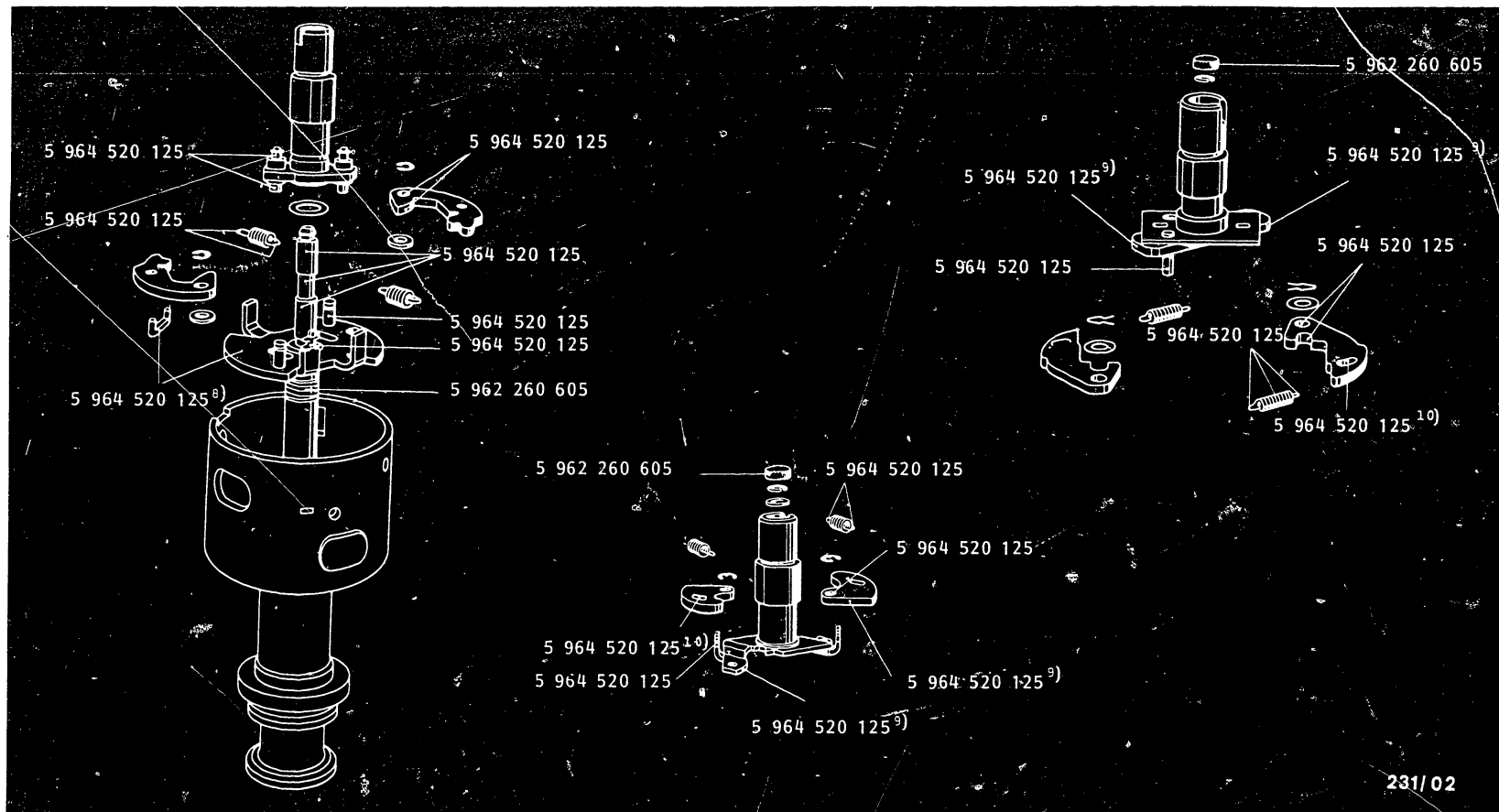

231/02

WG advance mechanism (with plastic rubbing block)

Rolling-contact advance mechanism

Sliding-contact advance mechanism

Lubrication points and lubricants on the centrifugal advance mechanism

- 8) Grease the plastic rubbing block and running surface on shaft plate
- 9) Grease the sliding surface
- 10) Grease the sliding nipple and its running surface on shaft plate

A6	Lubrication table	↔
	ZV 0 231 ..., conv. to Hall generator	

A7	Lubrication table	←
	ZV 0 231 ..., conv. to Hall generator	

4. Testing

4.1 Test instructions

All speeds given in the test specifications refer to the drive shaft of the ignition distributor. The direction of rotation of the distributor (viewed looking down on the distributor cap) is given in the type designation, e.g.

IFU4 ← = clockwise rotation → = counterclockwise rotation

or

Z 415 ← = clockwise rotation → = counterclockwise rotation.

Caution!

The holding springs of the distributor cap must not fall into the generator system when the distributor shaft is driven with the dust-protection cover removed.

Be very careful when working with an open ignition distributor. No metal chips must be allowed to enter the generator system (the air gap could be bridged by a metal chip).

Only drive the ignition distributor with the drive gear or coupling mounted in place (incorrect measurements can result from excessive longitudinal play in the distributor shaft).

Perform the measurements at room temperature and at the stated voltage.

The ignition vane switch will be destroyed in the case of incorrect polarity.

B1

Testing

ZV 0 231 ..., conv. to Hall generator



4.2 Visual examination

The distributor cap and the distributor rotor must be clean and must have no cracks or leakage paths.

The original lead must be installed and the connections must be tight and not damaged.

The distributor rotor, trigger wheel and ignition vane switch must not show any damage and the distributor rotor must be firmly positioned on the distributor shaft. It must be possible to turn the distributor shaft by hand and the trigger wheel must not graze the ignition vane switch.

B2

Testing

ZV 0 231 ..., conv. to Hall generator



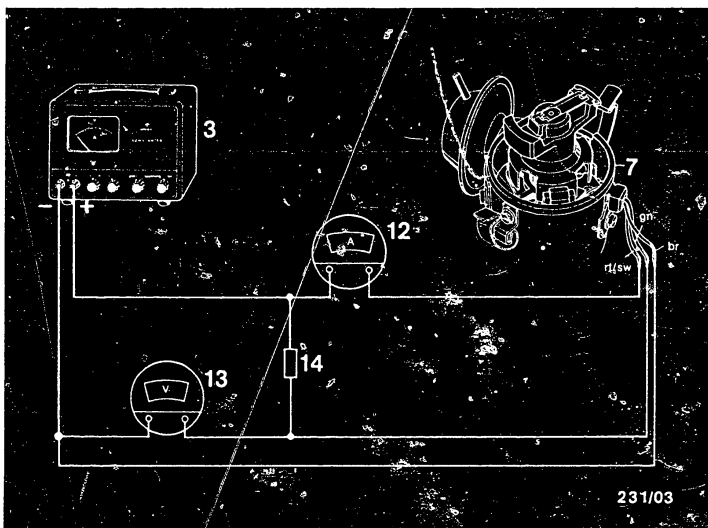

- 3 = Voltage stabilizer/battery
 7 = Ignition distributor
 12 = Ammeter
 13 = Voltmeter
 14 = Resistor 1.5 kΩ

- br = brown
 gn = green
 rt = red
 sw = black

4.3 Testing the generator system ignition vane switch "on"

Mount the distributor on the distributor test bench. Switch on the voltage stabilizer and set to 12 V. Switch off the voltage stabilizer. Connect the components and testers in accordance with the above terminal diagram.

B3

Testing

ZV 0 231 ..., conv. to Hall generator



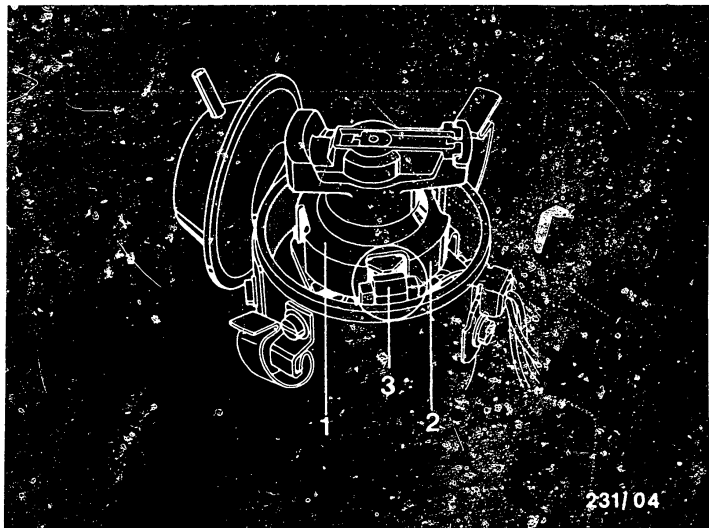

- 1 = Trigger wheel
- 2 = Vane
- 3 = Ignition vane switch

Turn distributor shaft by hand until vane is outside air gap of ignition vane switch (see illustration).

Switch on voltage supply.

The voltmeter may indicate max. 0.4 V, the ammeter max. 20 mA.

B4

Testing

ZV 0 231 ..., conv. to Hall generator



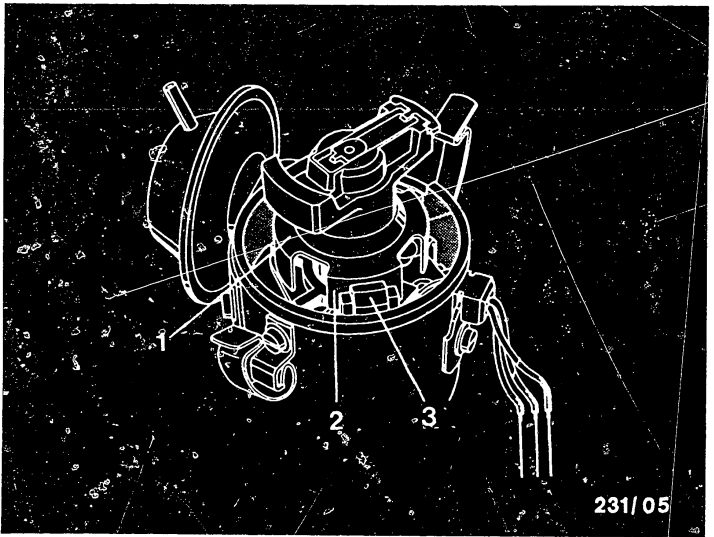

- 1 = Trigger wheel
- 2 = Vane
- 3 = Ignition vane switch

4.4 Testing the generator system ignition vane switch "off"

Turn distributor shaft by hand until vane (2) is completely in air gap of ignition vane switch (3) (see illustration).

The voltmeter must indicate min. 11V.

If the stated values are not reached, the ignition vane switch is defective.

Switch off the voltage supply.

B5

Testing

ZV 0 231 ..., conv. to Hall generator



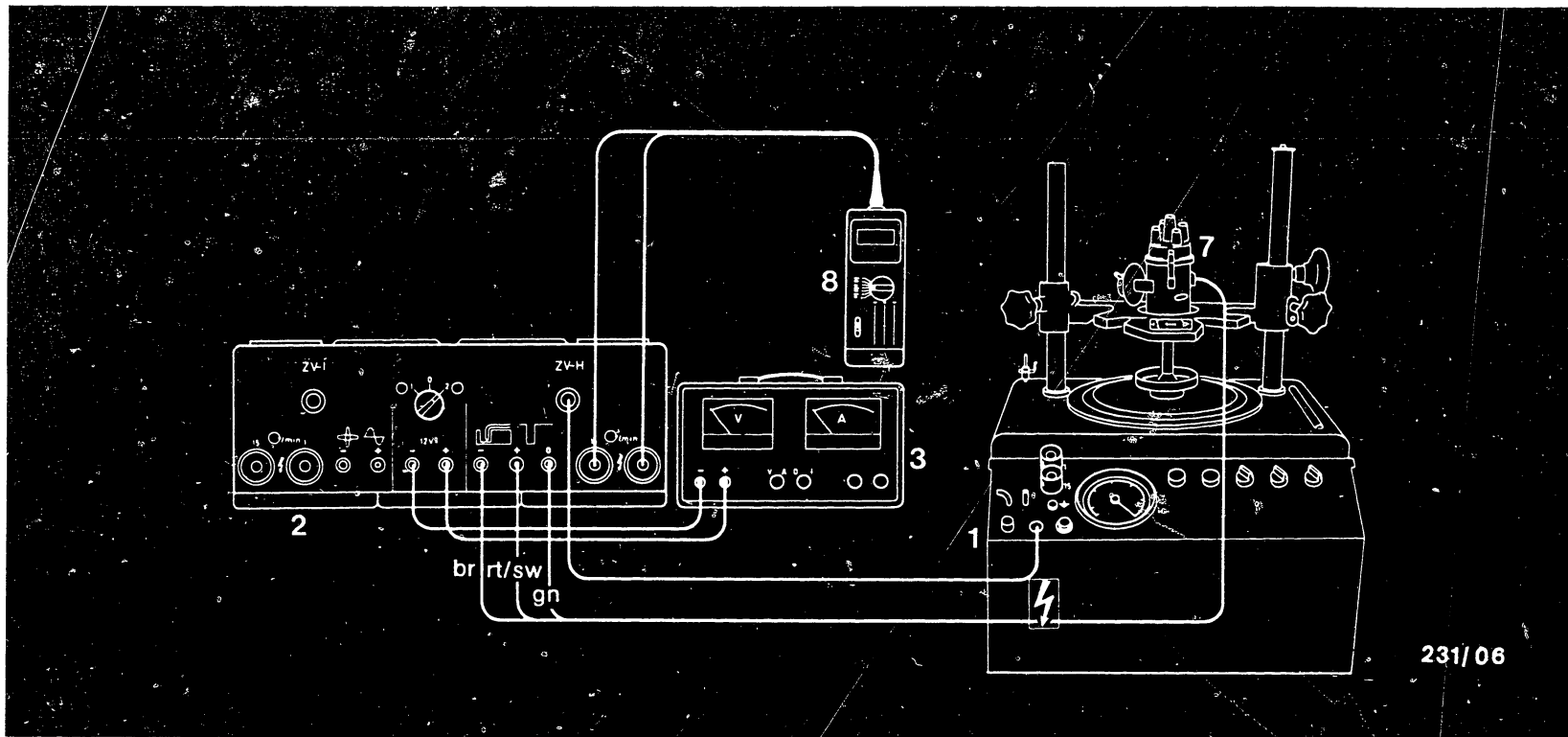

Terminal diagram

1 = Distributor test bench

2 = Distributor test adapter (ZV-H)

3 = Voltage stabilizer/battery

7 = Ignition distributor

8 = Tachometer

br = brown

gr = green

rt = red

sw = black

4.5 Testing the centrifugal advance (test specifications VDT-WPE 120/2...21 and VDT-W 231/1001 etc.)

For testing the centrifugal and vacuum advance curve, use only the ZV-H test adapter KDZV 7202.

Connect the ignition distributor, testers and ZV-H test adapter in accordance with the above terminal diagram. Follow the operating instructions of the individual testers.

B6

Testing

ZV 0 231 ..., conv. to Hall generator

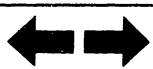

B7

Testing

ZV 0 231 ..., conv. to Hall generator



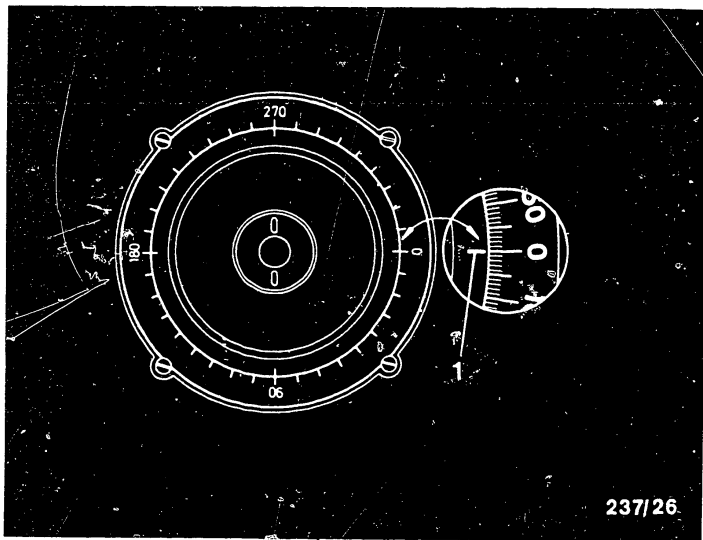

237/26

1 = Illuminated mark

Switch on the 12V voltage supply.

Drive the ignition distributor at a speed 100 min^{-1} below the speed of the earliest start of centrifugal advance (see test specifications).

Then turn the scale ring of the distributor test bench or the ignition distributor so that the illuminated mark of a cylinder lights up at $0^\circ/360^\circ$ (zero point). See illustration. Tighten locking screw of ignition distributor or clamping ring of chuck.

B8

Testing

ZV 0 231 ..., conv. to Hall generator

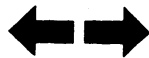

The most practical method of testing the centrifugal advance is to proceed so that each curve is checked at least twice in every range covered by a change in curve direction, and at least twice in the final control range. The test is only to be carried out with increasing speed. (This avoids measurement errors). Read off the advance angle and compare it with the test specifications. See figure for examples. If an addition to the tolerance range of $\pm 0.5^\circ$ is given in the test specifications, the upper line of the tolerance range must be extended by 0.5° to the top, and the lower line by 0.5° to the bottom. If the specified values are not reached, the ignition distributor (advance system) is defective.

Switch off the voltage supply.

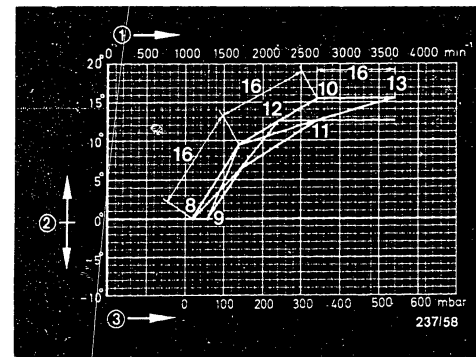

- 1 = Distributor-shaft speed
- 2 = Distributor-shaft advance
- 3 = Negative gauge pressure (vacuum)
- 8/9 = Start of centrifugal advance
- 10/11 = End of centrifugal advance
- 12/13 = In extreme cases the end of centrifugal advance may be located here
- 16 = Change in curve direction

B9

Testing

ZV 0 231, conv. to Hall generator



B10

Testing

ZV 0 231, conv. to Hall generator



Advance curve with "adjustment base" (19)

After the zero point adjustment of the distributor test bench (scale ring) it is possible, without the centrifugal advance operating, for there already to be a slight advance (max. 0.5°) although the actual centrifugal advance only starts at points 8/9.

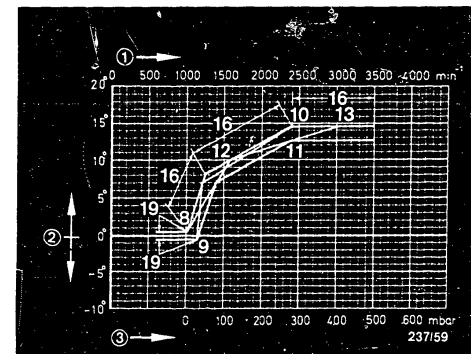

- 1 = Distributor-shaft speed
- 2 = Distributor-shaft advance
- 3 = Negative gauge pressure (vacuum)
- 8/9 = Start of centrifugal advance
- 10/11 = End of centrifugal advance
- 12/13 = In extreme cases the end of centrifugal advance may be located here
- 16 = Change in curve direction
- 19 = "Adjustment base"

B11

Testing

ZV 0 231 ..., conv. to Hall generator



B12

Testing

ZV 0 231 ..., conv. to Hall generator



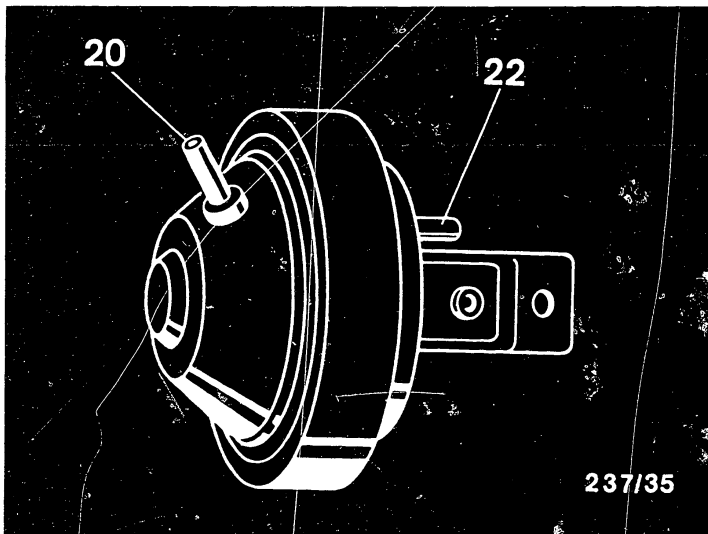

237/35

20 = Vacuum connection "advance"

22 = Vacuum connection "retard"

Note: According to DIN the term "vacuum" should be replaced by negative "gauge pressure". For the sake of clarity, however, we will continue to use "vacuum".

4.6 Testing the vacuum advance

4.6.1 Testing the vacuum unit for leaks (not given in test specifications)

Connect the vacuum hose from the distributor test bench to the vacuum unit.

Using the vacuum pump, increase the vacuum until 600 mbar is reached. Switch off the vacuum pump.

B 13

Testing

ZV 0 231 ..., conv. to Hall generator



The maximum permissible pressure drop in 1 minute is 20%. Remedy any leaks found at the connection. Replace vacuum-advance mechanism if leaking.

B14

Testing

ZV 0 231 ..., conv. to Hall generator



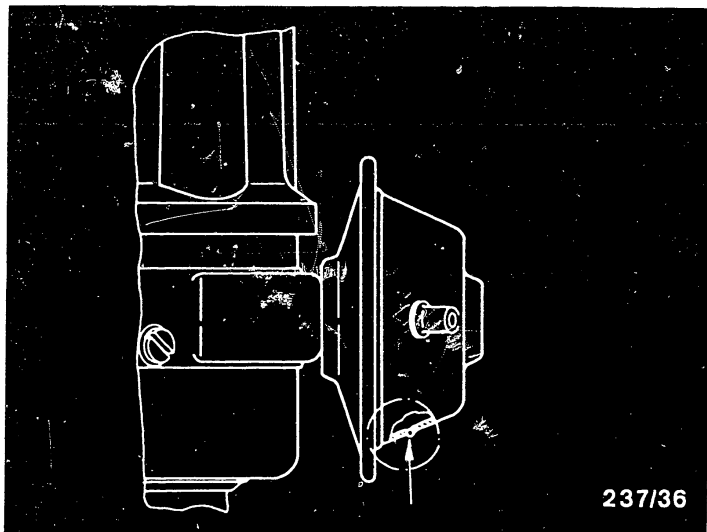

If there is an extremely heavy drop in pressure, check whether the vacuum unit is of the type which has a vent hole (approx. 0.5 mm diameter). See picture, arrow.
Seal off the hole while testing for leaks.

B 15

Testing

ZV 0 231 ..., conv. to Hall generator



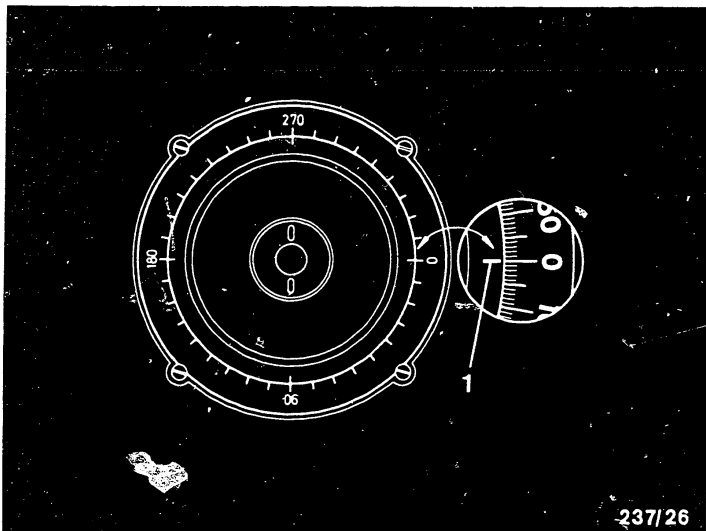

1 = Illuminated mark

4.6.2 Testing the vacuum advance (test specifications VDT-WPE 120/2...21 and VDT-W-231/1001 etc.

Mount the ignition distributor and connect to testers and specified test adapter. Switch on the 12V voltage supply. Drive the ignition distributor at a speed 200 min^{-1} above the end of centrifugal advance (see test specifications).

Then turn the scale ring of the distributor test bench or the ignition distributor so that the illuminated mark of a cylinder lights up at $0^\circ/360^\circ$ (zero point). See illustration.

Tighten locking screw of ignition distributor or clamping ring of chuck.

B 16

Testing

ZV 0 231 ..., conv. to Hall generator



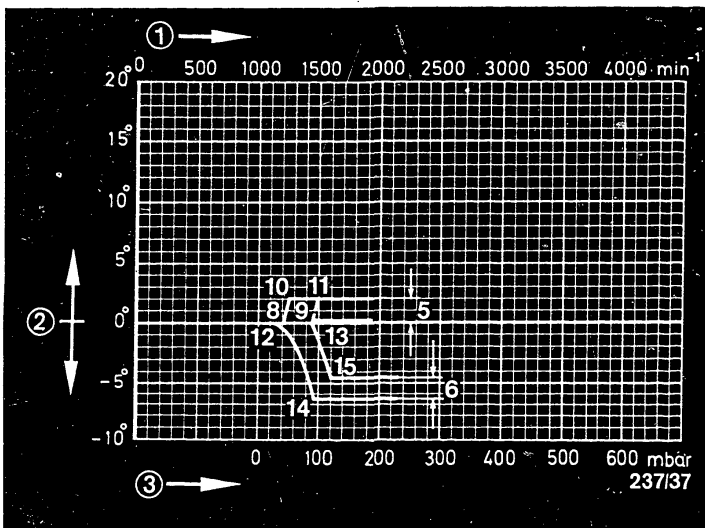

- | | |
|--|--|
| 1 = Distributor-shaft speed | 8/9, 12/13 start of vacuum advance "advance and retard unit" |
| 2 = Distributor-shaft advance | 10/11, 14/15 end of vacuum advance "advance and retard unit" |
| 3 = Negative gauge pressure (vacuum) | |
| 5 = Negative gauge pressure (vacuum) advance | |
| 6 = Negative gauge pressure (vacuum) retard | |

With increasing vacuum, check whether the advance angle is within the stated tolerance range. See figure for example.

If an addition to the tolerance range of $\pm 0.5^\circ$ is given in the test specifications, the upper line must be extended by 0.5° to the top and the lower line by 0.5° to the bottom.

B17

Testing

ZV 0 231 ..., conv. to Hall generator



If the measured values are not within the tolerance range, then check the breaker-plate assembly and the tie rod for freedom of movement.
 After reaching the end of advance, an increase in the vacuum must not result in a further advance.

Switch off the voltage supply.

Advance curve with "adjustment base" (19)

After the zero-point adjustment of the distributor test bench (scale ring) it is possible, with increasing vacuum, for there already to be a slight advance (max. 0.5°) although the actual vacuum advance only starts at points 8/9 or 12/13.

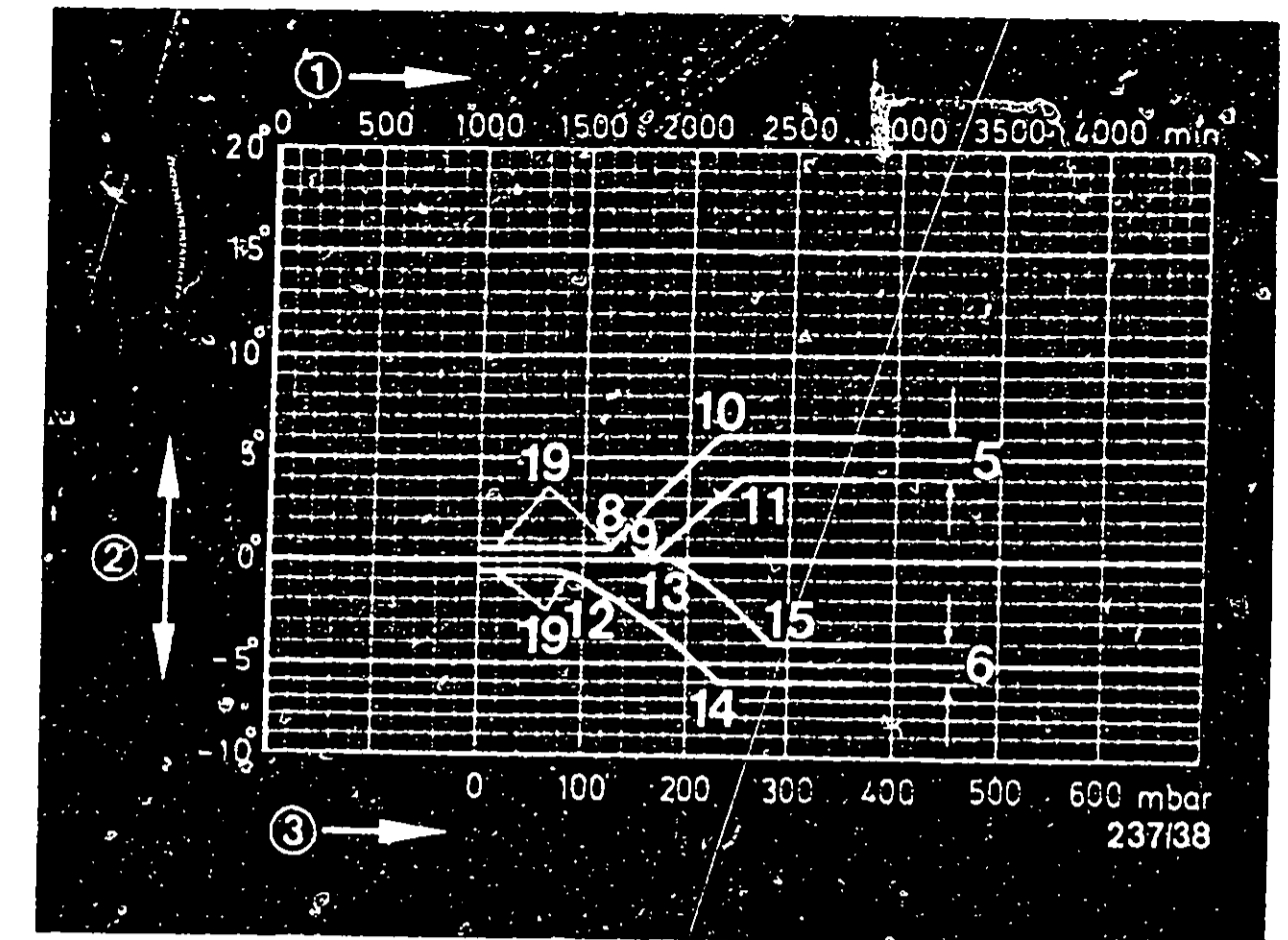

- 1 = Distributor-shaft speed
- 2 = Distributor-shaft advance
- 3 = Negative gauge pressure (vacuum)
- 5 = Negative gauge pressure (vacuum) advance
- 6 = Negative gauge pressure (vacuum) retard
- 8/9, 12/13 = Start of vacuum advance "advance and retard unit"
- 10/11, 14/15 = End of vacuum advance "advance and retard unit"
- 19 = "Adjustment base"

B 18

Testing

ZV 0 231 ..., conv. to Hall generator



B 19

Testing

ZV 0 231 ..., conv. to Hall generator



4.7 Testing the vacuum/overpressure advance - pressure unit with one or two connecting pipes (test specifications VDT-WPE 120/2...21 and VDT-W-231/1001 etc.).

4.7.1 Testing the vacuum or overpressure unit for leaks
(not given in test specifications)

Connect the vacuum hose from the distributor test bench to the pressure unit.

In the case of the vacuum/overpressure unit with double retard, the overpressure unit is also tested for leaks using vacuum.

In the case of the vacuum/overpressure unit with one connecting pipe, the advance and retard unit is tested for leaks using vacuum.

Using the vacuum pump, increase the vacuum until 600 mbar is reached. Switch off the vacuum pump.

The max. permissible pressure drop in 1 minute is 20%. Remedy any leaks at the connection. Replace vacuum-advance mechanism if leaking.

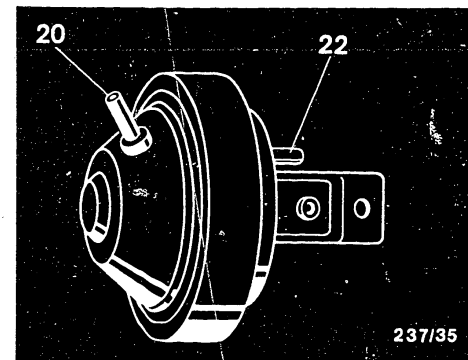

237/35

20 = Vacuum connection
"retard"

22 = Overpressure connection
"retard"

23 = Vacuum connection
"advance"
and
overpressure connection
"retard"

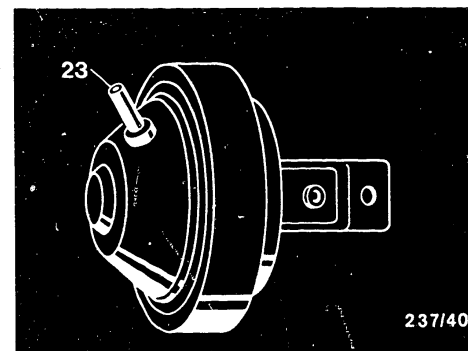

237/40

B20

Testing

ZV 0 231 ..., conv. to Hall generator



B21

Testing

ZV 0 231 ..., conv. to Hall generator



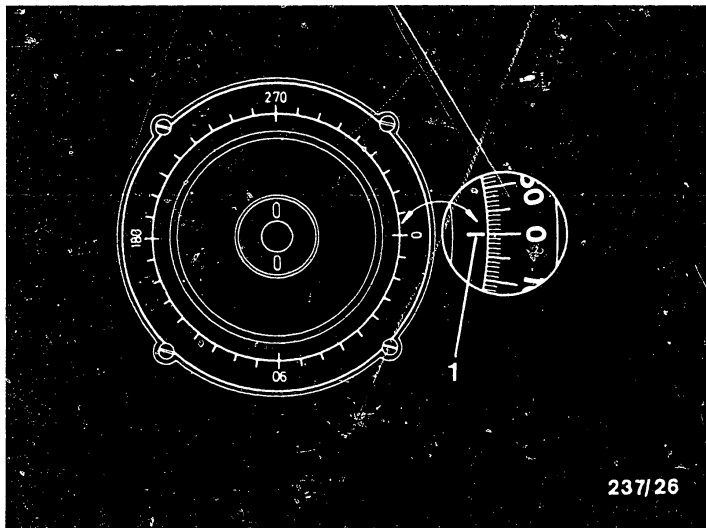

1 = Illuminated mark

4.7.2 Testing the vacuum advance

Mount the ignition distributor and connect to testers and specified test adapter. Switch on the 12V voltage supply.

Drive the ignition distributor at a speed 200 min^{-1} above the end of centrifugal advance (see test specifications). Then turn the scale ring of the distributor test bench or the ignition distributor so that the illuminated mark of a cylinder lights up at $0^\circ/360^\circ$. See illustration.

Tighten locking screw of ignition distributor or clamping ring of chuck.

C1

Testing

ZV 0 231 ..., conv. to Hall generator



With increasing vacuum, check whether the advance angle is within the stated tolerance range. See figure for example.

If an addition to the tolerance range of $\pm 0.5^\circ$ is given in the test specifications, the upper line must be extended by 0.5° to the top, and the lower line by 0.5° to the bottom.

If the measured values are not within the tolerance range, then check the breaker-plate assembly and the tie rod for freedom of movement.

After reaching the end of advance, an increase in the vacuum must not result in any further advance.

Advance curve with "adjustment base" (19)

After the zero-point adjustment of the distributor test bench (scale ring) it is possible, with increasing vacuum, for there already to be a slight advance (max. 0.5°) although the actual vacuum advance only starts at point 8/9.

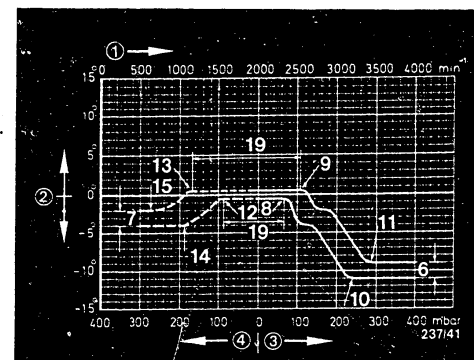

- 1 = Distributor-shaft speed
- 2 = Distributor-shaft advance
- 3 = Negative gauge pressure (vacuum)
- 4 = Gauge pressure
- 6 = Negative gauge pressure (vacuum) retard
- 7 = Gauge pressure retard
- 8/9, 12/13 = Start of vacuum/overpressure advance with double retard
- 10/11, 14/15 = End of vacuum/overpressure advance with double retard
- 19 = "Adjustment base"

C2

Testing

ZV 0 231 ..., conv. to Hall generator



C3

Testing

ZV 0 231 ..., conv. to Hall generator



Further example of an advance curve, e.g. vacuum advance

Advance curve with "adjustment base" (19)

After the zero-point adjustment of the distributor test bench (scale ring) it is possible, with increasing vacuum, for there to be a slight advance (max. 0.5°) although the actual vacuum advance only starts at point 12/13.

Note

The double unit with one connecting pipe advances when vacuum is applied to it and retards when overpressure is applied to it.

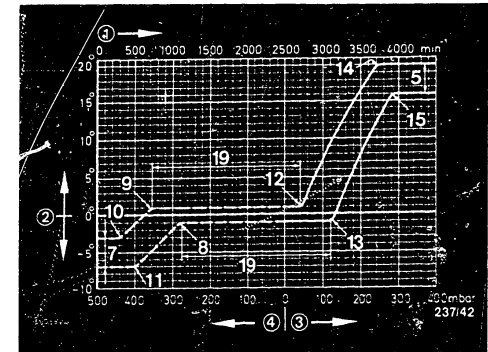

- 1 = Distributor-shaft speed
- 2 = Distributor-shaft advance
- 3 = Negative gauge pressure (vacuum)
- 4 = Gauge pressure
- 5 = Negative gauge pressure (vacuum) advance
- 7 = Gauge pressure retard
- 8/9, 12/13 = Start of vacuum/overpressure advance with advance/retard
- 10/11, 14/15 = End of vacuum/overpressure advance
- 19 = "Adjustment base"

C4

Testing

ZV 0 231 ..., conv. to Hall generator



C5

Testing

ZV 0 231 ..., conv. to Hall generator

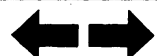

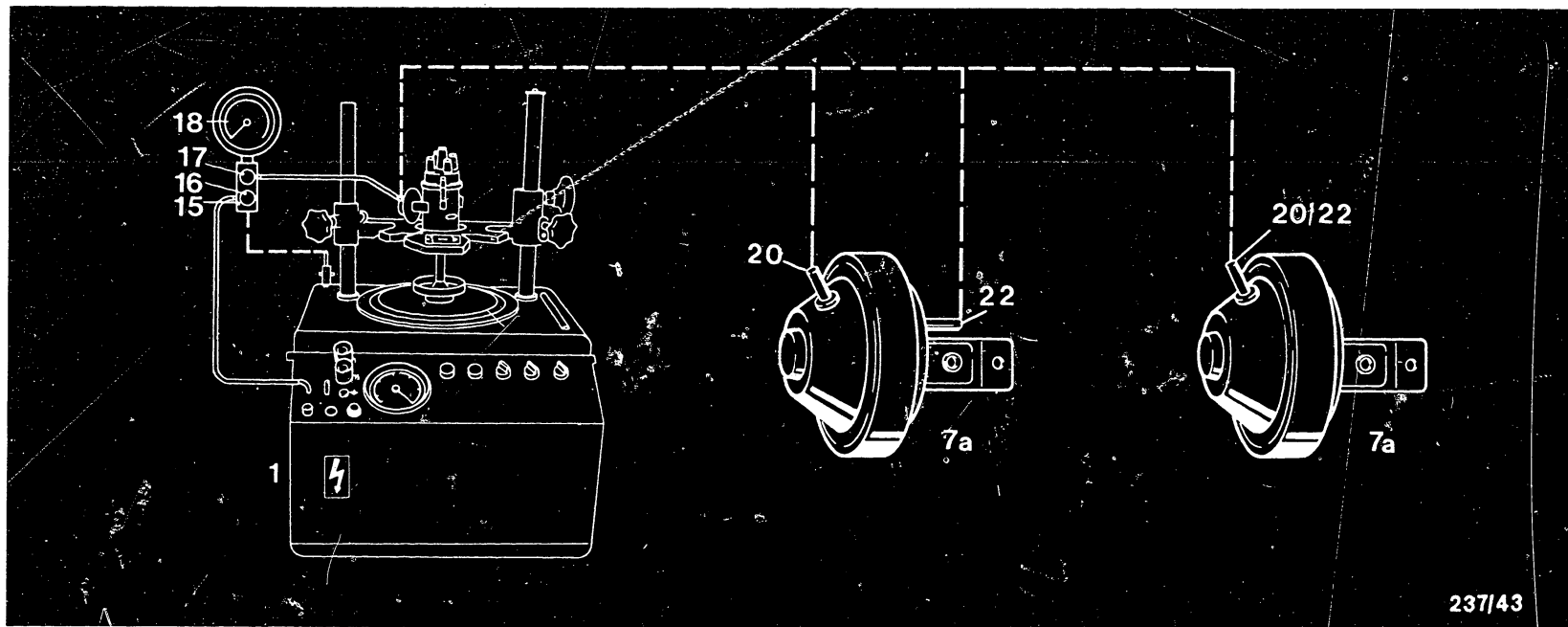

237/43

1 = Distributor test bench
 7a = Vacuum/overpressure unit
 15 = Adjustment throttle

16 = Adjusting screw
 17 = Screw plug
 18 = Pressure gauge

20 = Vacuum connection "retard"
 22 = Overpressure connection "retard"

4.7.3 Testing the overpressure advance

Mount the ignition distributor on the distributor test bench.

Connect the overpressure connection of the distributor test bench to the lower connection of the adjustment throttle. Connect the overpressure connection of the ignition distributor to the upper connection of the adjustment throttle. See connection diagram above.

Note: Adjusting screw (16) is for setting the pressure. If a pressure of 1.2 bar is not reached, then screw out the adjusting screw (16) and coat the thread with tough grease. Re-fit the adjusting screw (16). The screw plug (17) is open while testing.

C6

Testing

ZV 0 231 ..., conv. to Hall generator



C7

Testing

ZV 0 231 ..., conv. to Hall generator



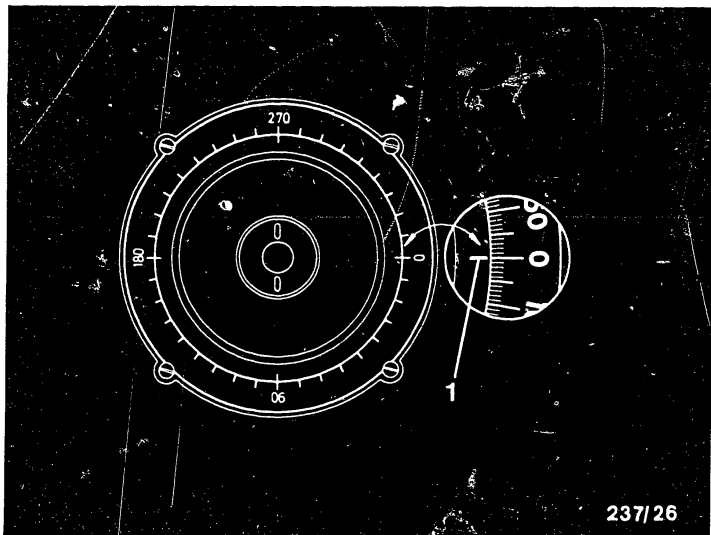

237/26

1 = Illuminated mark

Connect the ignition distributor to testers and specified test adapter. Switch on the 12V voltage supply.

Drive the ignition distributor at a speed 200 min^{-1} above the end of centrifugal advance (see test specifications). Then turn the scale ring of the distributor test bench or the ignition distributor so that the illuminated mark of a cylinder lights up at $0^\circ/360^\circ$. See illustration.

Tighten locking screw of ignition distributor or clamping ring of chuck.

C8

Testing

ZV 0 231 ..., conv. to Hall generator

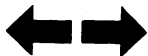

With increasing overpressure, check whether the advance angle is within the stated tolerance range. See figure for example.

If an addition to the tolerance range of $\pm 0.5^\circ$ is given in the test specifications, the upper line must be extended by 0.5° to the top and the lower line by 0.5° to the bottom. If the measured values are not within the tolerance range, check the breaker-plate assembly and tie rod for freedom of movement.

After reaching the end of advance, an increase in the overpressure must not result in any further advance.

Advance curve with "adjustment base" (19)

After the zero-point adjustment of the distributor test bench (scale ring) it is possible, with increasing overpressure, for there already to be a slight advance (max. 0.5°) although the actual overpressure advance only starts at point 12/13.

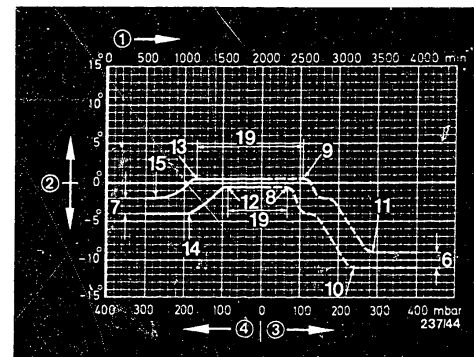

- 1 = Distributor-shaft speed
- 2 = Distributor-shaft advance
- 3 = Negative gauge pressure (vacuum)
- 4 = Gauge pressure
- 6 = Negative gauge pressure (vacuum) retard
- 7 = Gauge pressure retard
- 8/9, 12/13 = Start of vacuum/overpressure advance with double retard
- 10/11, 14/15 = End of vacuum/overpressure advance with double retard
- 19 = "Adjustment base"

C9

Testing

ZV 0 231 ..., conv. to Hall generator



C10

Testing

ZV 0 231 ..., conv. to Hall generator



Further example of an advance curve, e.g. overpressure retard

Advance curve with "adjustment base" (19)

After the zero-point adjustment of the distributor test bench (scale ring) it is possible, with increasing overpressure, for there already to be a slight advance (max. 0.5°) although the actual overpressure advance only starts at point 8/9.

Note: The double unit with one connecting pipe advances when vacuum is applied to it and retards when overpressure is applied to it.

Switch off the voltage supply.

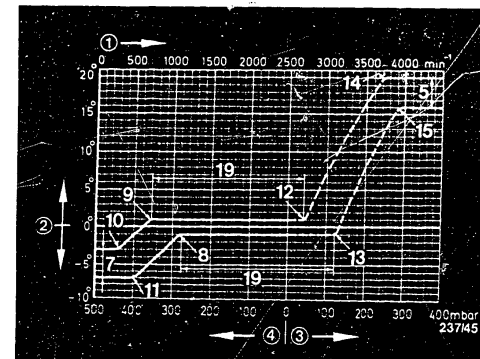

- 1 = Distributor-shaft speed
- 2 = Distributor-shaft advance
- 3 = Negative gauge pressure (vacuum)
- 4 = Gauge pressure
- 5 = Negative gauge pressure (vacuum) advance
- 7 = Gauge pressure retard
- 8/9, 12/13 = Start of vacuum/overpressure advance with advance/retard
- 10/11, 14/15 = End of vacuum/overpressure advance
- 19 = "Adjustment base"

C11

Testing

ZV 0 231 ..., conv. to Hall generator



C12

Testing

ZV 9 231 ..., conv. to Hall generator



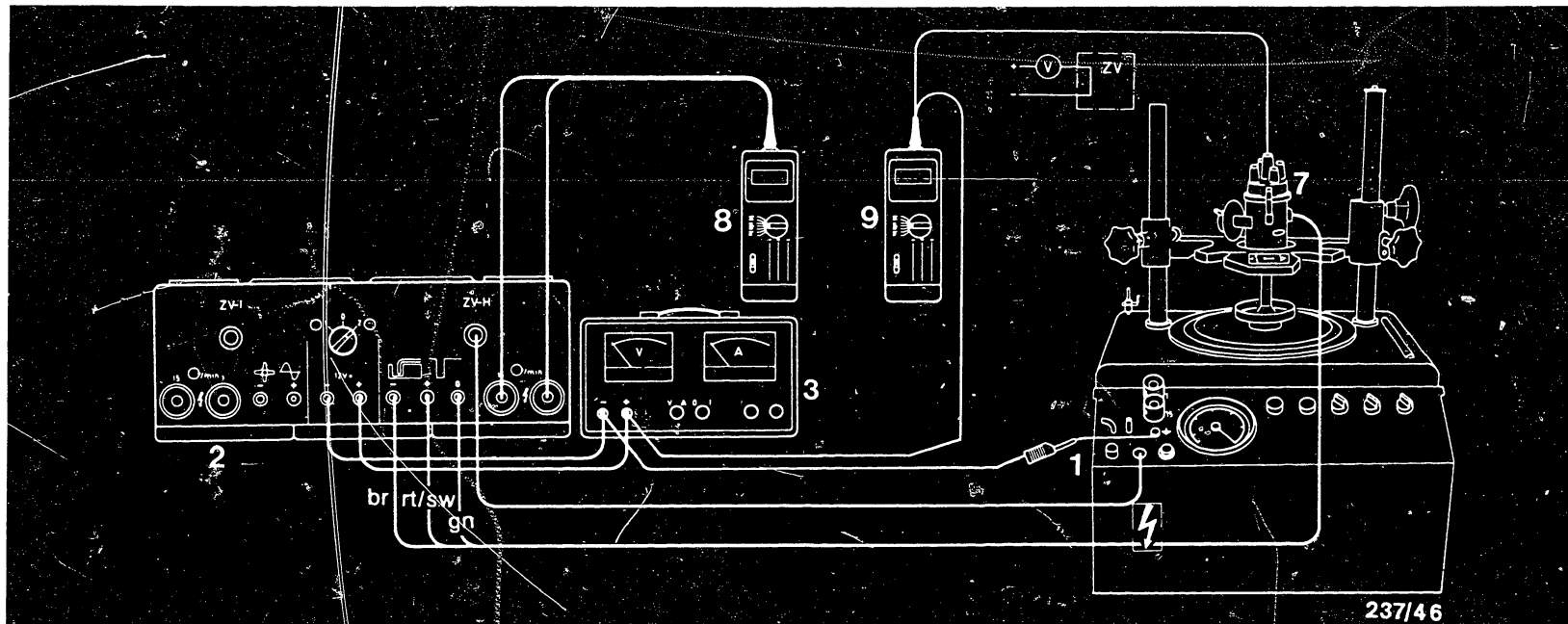

Terminal diagram

1 = Distributor test bench
2 = Distributor test adapter (ZV-H)

3 = Voltage stabilizer/battery
7 = Ignition distributor

8 = Tachometer
9 = Voltmeter
br = brown rt = red
gn = green sw = black

5. Testing the engine-speed limiter (test specifications VDT-WPE 120/2...21 and VDT-W 231/1001 etc.)

Mount the ignition distributor and connect to testers in accordance with above terminal diagram. Follow the operating instructions of the individual testers.

Switch on the 12V voltage supply.

Drive the ignition distributor at the specified speed.

The engine-speed limiter is O.K. if, up to the specified minimum speed, the voltmeter does not indicate voltage and if, as of the specified max. speed, it indicates voltage.

Switch off the voltage supply.

C13

Testing

ZV 0 231 ..., conv. to Hall generator

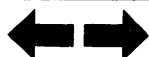

C14

Testing

ZT 0 231 ..., conv. to Hall generator



After-sales Service

Technical Bulletin

Only for use within the Bosch organization. Not to be communicated to any third party.

Breakerless Ignition Distributor 0231... with retrofitted Hall generator

23

VDT-I-231/101 B
1.1977

General

For the new breakerless, maintenance-free transistorized ignition system from Bosch.

Modification set for vehicles with 4-cylinder engine and Bosch ignition distributor, in some cases for vehicles as far back as the 1972 model. See also VDT-I-227/2 B, VDT-I-231/1 B and KH-Information "New breakerless, maintenance free transistorized ignition system TSZ-h".

Ignition Distributor - Modification

Lift off the distributor cap (1). Remove the distributor rotor (2) and dust-protection cover (3).

Remove distributor contact points (4).

Cut the ground connection (copper stranded wire) from the breaker-plate assembly to the distributor housing at both points of connection and remove it (see Fig. 2).

Unscrew ignition condenser (5) and remove together with connecting leads.

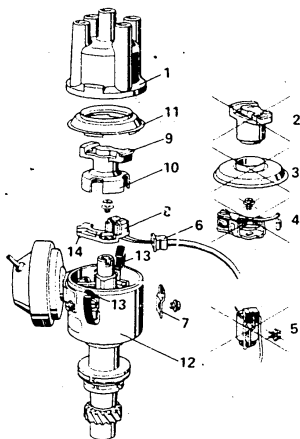

Fig. 1

Feed the leads of the ignition vane switch through the opening in the distributor from the inside and press the shaped piece (6) into the opening.

The shaped piece should be so positioned that the three thin leads are in its lower-half.

Do not twist the leads to the vane switch.

Slip the metal holder (7) into the groove in the shaped piece and screw in place with the short screw supplied. Snap the ignition vane switch (8) with locating piece (14) into the breaker-plate assembly and screw in place with the long screw provided.

- | | |
|-------------------------------|------------------------------|
| 1 = Distributor cap | 10 = Trigger wheel |
| 2 = Distributor rotor | 11 = Dust protection cover |
| 3 = Dust protection cover | 12 = Distributor housing |
| 4 = Contact point | 13 = Spring clip |
| 5 = Ignition condenser | 14 = Locating piece |
| 6 = Shaped piece | X = Parts no longer required |
| 7 = Sheet metal holder | |
| 8 = Ignition vane switch | |
| 9 = Distributor rotor with 10 | |

BOSCH

Geschäftsbereich KH, Kundendienst, Kfz-Ausstattung
© by Robert Bosch GmbH, D-7 Stuttgart 1 Postfach 50. Printed in the Federal Republic of Germany.
Imprimé en République Fédérale d'Allemagne par Robert Bosch GmbH

L1

Technical Bulletins

ZV 0 231 ..., conv. to Hall generator



Slip (snap in place) the new distributor rotor (9) with trigger wheel (10) onto the ignition-distributor shaft.

Place the new dust-protection cover (11) over the distributor housing (12) and snap into place.

Fit the distributor cap and secure with the spring clips (13).

Slip the insulating tubing over the ignition vane switch leads.

Caution! The ignition vane switch will be destroyed if the polarity is wrong.

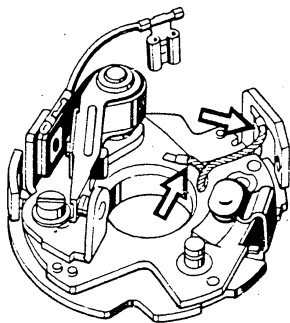

Fig. 2



After-sales Service

Technical Bulletin

Only for use within the Bosch organization. Not to be communicated to any third party.

RETROFITTING OF TCI-h

in vehicles with short-type ignition distributor
0 231 186 ..

VDT-I-231/103 En

8.1980

The short-type ignition distributor 0 231 186 .. (with contact breaker) cannot be converted to a breakerless type by fitting a Hall pulse generator.

Reason

For design reasons, the distributor shaft in this type of ignition distributor is also supported by a bushing above the breaker-plate assembly. Due to the upper bushing plate, it is impossible to push a distributor rotor together with trigger wheel onto the distributor shaft (in this connection see VDT-I-230/101).

Those vehicles which are equipped with a short-type ignition distributor though, can be retrofitted with breaker-triggered transistorized ignition system TCI-c, 0 227 051 906.

At present, the following vehicles are equipped with the short-type distributor:

VAG (VW/Audi)

Audi 50 with 1.1/1.3 l engine
Audi 80 (4000) with 1.3 l engine
Polo, Derby with 0.3 ... 1.3 l engine
Golf (Rabbit), Scirocco with 1.1 l engine
Passat (Dasher), Jetta with 1.3 l engine

Opel

Opel Kadett D with 1.7 l engine.

BOSCH

Geschäftsbereich für Kundendienst Kfz-Ausbildung
© by Robert Bosch GmbH, D-7 Stuttgart 1, Postfach 50. Printed in the Federal Republic of Germany
Imprimé en République Fédérale d'Allemagne par Robert Bosch GmbH

L3

Technical Bulletins

ZV 0 231 ..., conv. to Hall generator



Table of contents

Section	Coordinate
Microfiche layout	A 1
1. Test specifications	A 2
2. Necessary testers, auxiliary equipment	A 3
3. Lubricants	A 4
3.1 Lubrication table	A 4
4. Testing	B 1
4.1 Test instructions	B 1
4.2 Visual examination	B 2
4.3 Testing the generator system - ignition vane switch "on"	B 3
4.4 Testing the generator system - ignition vane switch "off"	B 5
4.5 Testing the centrifugal advance	B 6
4.6 Testing the vacuum advance	B 13
4.6.1 Testing the vacuum unit for leaks	B 13
4.6.2 Testing the vacuum advance	B 16
4.7 Testing the vacuum/overpressure advance - pressure unit with one or two connecting pipes	B 20
4.7.1 Testing the vacuum or overpressure unit for leaks	B 20
4.7.2 Testing the vacuum advance	C 1
4.7.3 Testing the overpressure advance	C 6
5. Testing the engine-speed limiter	C 13
Technical Bulletins	L 1

